



## OPERATING MANUAL

---

# LASERTANK 4-360 GREEN

Line laser

①

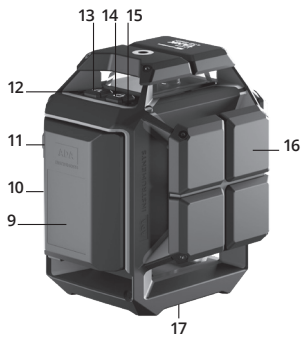
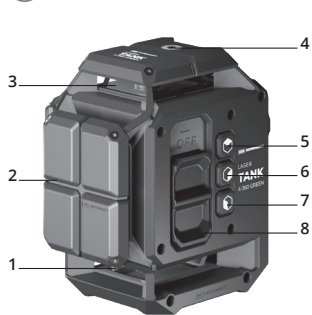

②



③

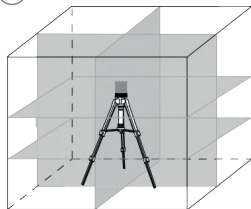

**THE MANUFACTURE RESERVES THE RIGHT TO MAKE CHANGES (NOT HAVING AN IMPACT ON THE SPECIFICATIONS) TO THE DESIGN, COMPLETE SET WITHOUT GIVING PRIOR WARNING.**

Line laser ADA LaserTANK 4-360 GREEN is designed to check the horizontal and vertical position of the surfaces of the elements of building structures and also to transfer the angle of inclination of the structural part to similar parts during construction and installation works.

### SPECIFICATIONS

<b>Laser beam</b> .....	2 horizontal lines 360°/ 2 vertical lines 360°
<b>Light sources</b> .....	4 laser diodes with laser emission wave length of 515 nm
<b>Laser safety class</b> .....	Class 2, <1mW
<b>Accuracy</b> .....	±3mm/10m
<b>Self-leveling range</b> .....	±4°
<b>Operating range with/ without receiver*</b> .....	230/130 ft (70/40 m)
<b>Dust/water protection</b> .....	IP 54
<b>Power source of the tool</b> .....	Li-ion battery 3.7 V / charger 5 V
<b>Power source of remote control</b> .....	12 V (type A27)
<b>Tripod thread</b> .....	2 x 1/4"
<b>Operating temperature</b> .....	-10°C +50°C
<b>Weight (with batteries)</b> .....	730 g

\*depends on illumination

## FUNCTIONAL DESCRIPTION

- The device projects 2 vertical (simultaneously) and two horizontal (of your choice) lines.
- Quick self-leveling: when line accuracy is out of the range the laser line flashes and the warning sound is produced.
- Pendulum locking system for safe transportation.
- Intermediate pendulum locking system for slope operation.
- Indoor and outdoor performance function.
- Remote mode

①

## FEATURES

1. Lower horizontal laser window
2. Front vertical laser window
3. Top horizontal laser window
4. Upper thread 1/4"
5. Horizontal laser beam (H) button
6. Side vertical (V) laser beam button
7. Front vertical (V) laser beam button
8. Pendulum switch (ON/OFF)
9. Removable battery
10. Power indication
11. Charger connector
12. Detector mode indicator
13. Detector mode
14. Slope mode
15. Slope mode indicator
16. Side vertical laser window
17. Bottom thread 1/4"

## ② REMOTE CONTROL

1. Side vertical (V) laser beam button
2. All laser lines On/Off button
3. Horizontal (H) laser lines On/Off button
4. Front vertical (V) laser line button

## ③ LASER LINES

Laser lines scheme is shown in the picture

### SAFETY INSTRUCTIONS

- Please follow up instructions given in operating manual.
- Do not stare into beam. Laser beam can lead to eye injury (even from greater distances).
- The laser line should be set up so that the beam path is not at normal eye level.
- Use the instrument for measuring jobs only.
- Do not open instrument housing. Repairs should be carried out by authorized workshops only. Please contact your local dealer.
- Do not remove warning labels or safety instructions.
- Keep instrument away from children.
- Do not use instrument in explosive environment.

### PREPARATION BEFORE OPERATION

1. Check the battery power before operation: press button (10) near the battery power indicator. The quantity of flashing bars shows the power level. All bars are flashing when the battery is fully charged. If the bars do not flash or only few bars are flashing, charge the battery or replace (if available) the battery.
2. To change the battery, press the latch on the bottom part of the battery and gently pull the case to remove it. Place a fully charged battery instead of

the lower power battery. When installing, gently press down on the battery housing until the latch clicks into place. Before installation, check the battery charge using the indicator.

3. To charge the battery, use the charger which is supplied with the tool (if available) or a charger with a maximum output voltage of 5 V and a USB-C connector. To connect the charger, use the connector on the battery (11). Gently pull the rubber cap. The cap is attached to the battery housing with one edge. Don't tear it off! Check the battery power with the indicator.

4. If you do not use the line laser for a long time (more than 24 hours), disconnect the battery. Otherwise the battery may be discharged below the permissible voltage. This may result in battery failure.

**WARNING: Do not leave the tool (battery) unattended while using charger. Parameters of the charger must correspond to the parameters of domestic electricity. Output voltage must be no more than 5V. Do not disassemble or heat the battery.**

## OPERATION

1. Set the pendulum switch (8) down to the (ON) position. Upper horizontal line is ON. If the switch is in the (ON) position, the line laser is switched on and a pendulum in a free position (is unlocked). The position of the pendulum switch (8) (OFF) means that the line laser is switched off and the pendulum is locked. If the line laser is set beyond the self-leveling range, an audible signal will sound, the laser lines and the indicator (15) will blink 1 time per second.

2. Laser beams can be turned on and off separately. To save battery power, turn on only the laser beams that are necessary for operation.

- press button (5) once – lower horizontal laser beam is ON. Press button (5) once again – all laser lines are ON. Press button (5) once again – upper horizontal line is OFF.
- press button (6) once – side vertical laser beam is ON. Press button (6) once again – side vertical laser line is OFF.

- press button (7) once – front vertical laser line is ON. Press button (7) once again - front vertical laser line is OFF.
3. The slope mode is activated when the pendulum is locked. Set the pendulum switch (8) up to the (OFF) position. Press and hold button (14) for 2 sec to activate a slope mode (upper horizontal laser line is ON, indicator is ON, all switched on laser lines will blink one time per sec.). The tool can be installed at any angle. Switch On/Off laser lines with the laser line buttons. Press button (14) to switch off a slope mode. Indicator (15) will be switched off.
4. Press button (13) once. Detector mode is activated. Indicator (12) is ON. Use a detector for operation in this mode. Follow an operating manual to use the detector. Press button (13) to switch OFF the detector mode. Indicator (12) is OFF.
5. Attach the line laser to the tripod with the help of the thread 1/4" on the upper or bottom part of the tool.

## USING THE REMOTE CONTROL

1. To control the functions of the device, the remote control must be paired with the device. If the remote control does not control the instrument functions, follow these steps:
- Be sure that the battery is full. If necessary, change it into new one: unscrew the screws on the back cover of the remote and remove it. Place new battery, observe the polarity. Screw the cover with the screws. If you cannot replace the battery yourself, contact the nearest service center.
  - To connect the remote control to the device, unlock the pendulum: move the pendulum switch (8) to the (ON) position. Press and hold button (13) for more than 2 sec. Indicator (12) starts blinking frequently. Press On/Off (2) button on the remote control. Indicator (12) will be switched off/ The remote will be connected to the line laser.
2. Use the remote control to switch on/off laser lines:

- Press button (2) once – all laser beams on will be turned off. Press button (2) once again – all laser beams that worked before turning off will turn on.
- Press button (3) once – lower horizontal laser line will be switched ON.
- Press button (3) once again – all horizontal laser beams will be ON. Press button (3) once again – upper horizontal laser beam will be switched OFF.
- Press button (1) once– side vertical laser beam will be switched ON.
- Press button (1) once again - side vertical laser beam will be switched OFF.
- Press button (4) once – front vertical laser beam will be switched ON.
- Press button (4) once again - front vertical laser beam will be switched OFF.

#### **TO CHECK THE ACCURACY OF LINE LASER**

##### **TO CHECK THE HORIZONTAL LASER LINE**

Place the line laser on the tripod 10 m away from the wall so the horizontal laser line will be directed to the wall. Switch on the power. The line laser starts to self-level. Mark point A on the wall to show the contact of laser beam with the wall. Turn the line laser by 90° and mark points B, C, D on the wall. Measure distance “h” between the highest and lowest points (these are A and D points in the picture). If “h” is  $\leq 6$  mm, the measurement accuracy is good. If “h” exceeds 6 mm, apply service center. Repeat these actions to check the horizontal laser line. Test results apply only to the tested beam.

##### **TO CHECK PLUMB**

Choose a wall and set laser 5m away from the wall. Hang a plumb with the cord about 2,5 m long on the wall. Switch ON the line laser and direct the vertical line to the plumb with the cord. The accuracy of the line is within acceptable limits if the deviation of the vertical line (up or down) does not exceed half the value of the “accuracy” characteristic (+/-3mm per 10m). If the accuracy of the line laser does not correspond to the declared one, it is



necessary to contact an authorized service center.

**Note: Due to the design of the laser emitter, discontinuity and different brightness intensity of the laser beam around the perimeter in different lighting conditions are allowed. Discontinuity of the laser beam: laser glare, but the middle of the beam is determined. Different laser beam brightness: up to 50% intensity difference.**

## PRODUCT LIFE

Product life of the tool is 5 years. Dispose of the device and its batteries separately from household waste. **Date of production, manufacturer's contact information, country of origin are indicated on the product sticker.**

## CARE AND CLEANING

Please handle line laser with care. Clean with soft cloth only after any use. If necessary damp cloth with some water. If instrument is wet clean and dry it carefully. Pack it up only if it is perfectly dry. Transport in original container/case only.

**Note: During transport On/Off pendulum lock (8) must be set to position "OFF". Disregard may lead to damage of pendulum.**

## SPECIFIC REASONS FOR ERRONEOUS MEASURING RESULTS

- Measurements through glass or plastic windows;
- Dirty laser emitting window;
- After instrument has been dropped or hit. Please check the accuracy.
- Large fluctuation of temperature: if instrument will be used in cold areas after it has been stored in warm areas (or the other way round) please wait some minutes before carrying out measurements.

## **ELECTROMAGNETIC ACCEPTABILITY (EMC)**

- It cannot be completely excluded that this instrument will disturb other instruments (e.g. navigation systems);
- will be disturbed by other instruments (e.g. intensive electromagnetic radiation nearby industrial facilities or radio transmitters).

## **LASER CLASS 2 WARNING LABELS ON THE LASER INSTRUMENT LASER CLASSIFICATION**

The instrument is a laser class 2 laser product according to DIN IEC 60825-1:2014. It is allowed to use unit without further safety precautions.

## **WARRANTY**

This product is warranted by the manufacturer to the original purchaser to be free from defects in material and workmanship under normal use for a period of two (2) years from the date of purchase. During the warranty period, and upon proof of purchase, the product will be repaired or replaced (with the same or similar model at manufacturer's option), without charge for either parts or labour.

In case of a defect please contact the dealer where you originally purchased this product. The warranty will not apply to this product if it has been misused, abused or altered. Without limiting the foregoing, leakage of the battery, bending or dropping the unit are presumed to be defects resulting from misuse or abuse.

---

## EXCEPTIONS FROM RESPONSIBILITY

- The user of this product is expected to follow the instructions given in operators' manual.
- Although all instruments left our warehouse in perfect condition and adjustment the user is expected to carry out periodic checks of the product's accuracy and general performance.
- The manufacturer, or its representatives, assumes no responsibility of results of a faulty or intentional usage or misuse including any direct, indirect, consequential damage, and loss of profits.
- The manufacturer, or its representatives, assumes no responsibility for consequential damage, and loss of profits by any disaster (earthquake, storm, flood ...), fire, accident, or an act of a third party and/or a usage in other than usual conditions.
- The manufacturer, or its representatives, assumes no responsibility for any damage, and loss of profits due to a change of data, loss of data and interruption of business etc., caused by using the product or an unusable product.
- The manufacturer, or its representatives, assumes no responsibility for any damage, and loss of profits caused by usage other than explained in the users' manual.
- The manufacturer, or its representatives, assumes no responsibility for damage caused by wrong movement or action due to connecting with other products.

**WARRANTY DOESN'T EXTEND TO FOLLOWING CASES:**

1. If the standard or serial product number will be changed, erased, removed or will be unreadable.
2. Periodic maintenance, repair or changing parts as a result of their normal runout.
3. All adaptations and modifications with the purpose of improvement and expansion of normal sphere of product application, mentioned in the service instruction, without tentative written agreement of the expert provider.
4. Service by anyone other than an authorized service center.
5. Damage to products or parts caused by misuse, including, without limitation, misapplication or negligence of the terms of service instruction.
6. Power supply units, chargers, accessories, wearing parts.
7. Products, damaged from mishandling, faulty adjustment, maintenance with low-quality and non-standard materials, presence of any liquids and foreign objects inside the product.
8. Acts of God and/or actions of third persons.
9. In case of unwarranted repair till the end of warranty period because of damages during the operation of the product, it's transportation and storing, warranty doesn't resume.

**WARRANTY CARD**

Name and model of the product \_\_\_\_\_

Serial number \_\_\_\_\_ Date of sale \_\_\_\_\_

Name of commercial organization \_\_\_\_\_

stamp of commercial organization

Warranty period for the instrument exploitation is 24 months after the date of original retail purchase.

During this warranty period the owner of the product has the right for free repair of his instrument in case of manufacturing defects.

Warranty is valid only with original warranty card, fully and clear filled (stamp or mark of the seller is obligatory).

Technical examination of instruments for fault identification which is under the warranty, is made only in the authorized service center.

In no event shall manufacturer be liable before the client for direct or consequential damages, loss of profit or any other damage which occur in the result of the instrument outage.

The product is received in the state of operability, without any visible damages, in full completeness. It is tested in my presence. I have no complaints to the product quality. I am familiar with the conditions of warranty service and I agree.

purchaser signature \_\_\_\_\_

Before operating you should read service instruction!

If you have any questions about the warranty service and technical support contact seller of this product



---

ADA International Group Ltd., No.6 Building, Hanjiang West Road #128,  
Changzhou New District, Jiangsu, China

Made In China

[adainstruments.com](http://adainstruments.com)

